

SECTION 5D4 POWERMASTER POWER BRAKE ASSEMBLY CONTENTS

GENERAL DESCRIPTION	5D4-2	Sump Hose, Tube & Nut Assembly,	
ON-CAR SERVICE	5D4-2	and Motor & Pump Brackets	5D4-3
Depressurizing Powermaster Unit	5D4-2	Powermaster Unit	5D4-3
Pressure Switch	5D4-2	UNIT REPAIR	5D4-4
Accumulator	5D4-2	Powermaster Overhaul	5D4-4
E-H Pump and Pressure Hose	5D4-3	POWERMASTER BLEED AND FILL	5D4-7

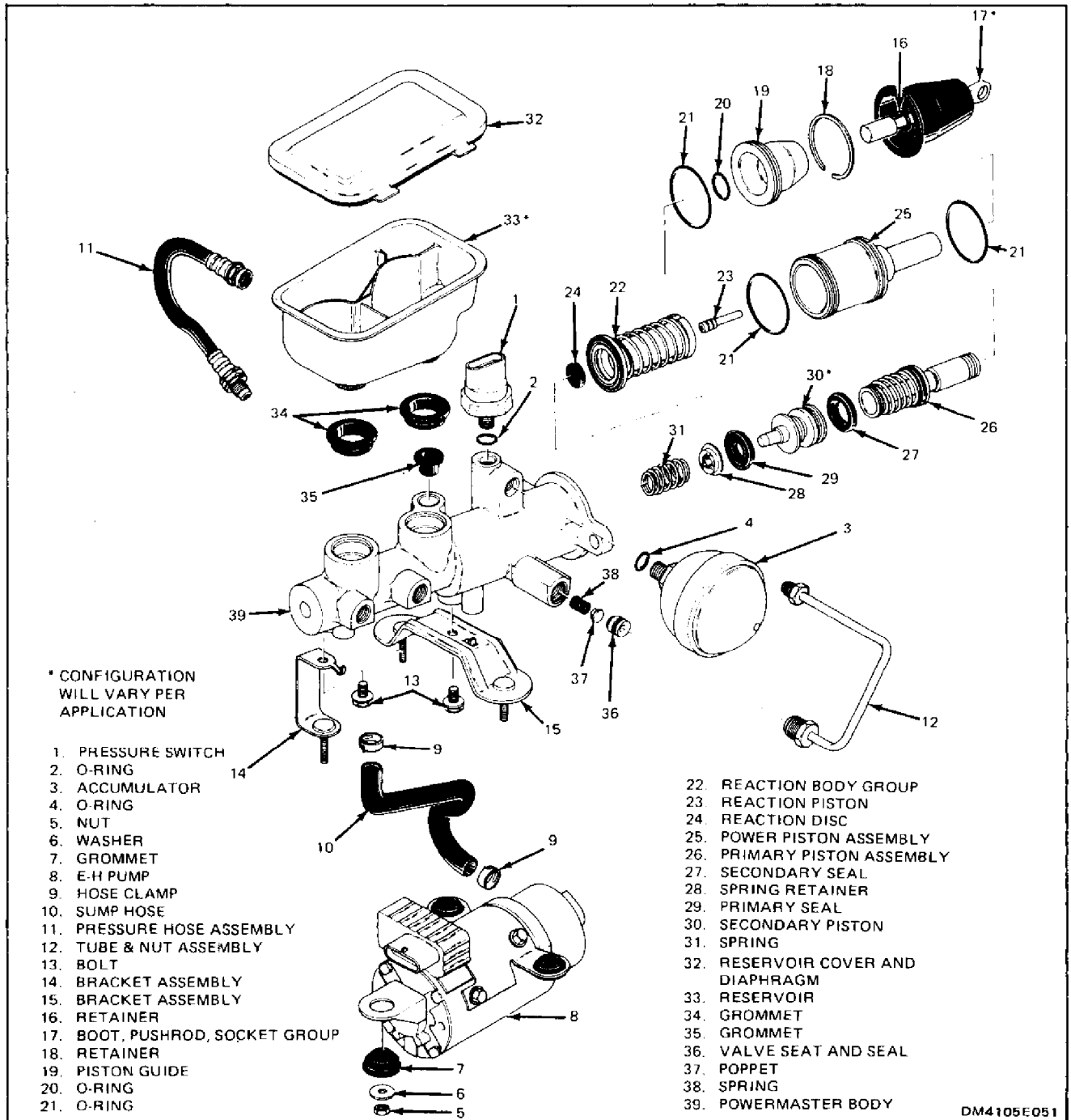

Figure 1

DM4105E051

GENERAL DESCRIPTION

This Powermaster unit is a complete, integral power brake apply system. It consists of an electro-hydraulic (E-H) pump, fluid accumulator, pressure switch, fluid reservoir, and a hydraulic booster with an integral dual master cylinder. The nitrogen charged accumulator stores fluid at 510-675 psig for hydraulic booster operation. The E-H pump operates between pressure switch limits with the ignition "ON". When the pressure switch senses accumulator pressure below 510 psig, the 12-volt E-H pump operates to increase accumulator fluid pressure to 675 psig. When the brake pedal is depressed, fluid from the accumulator acts on the booster power piston to apply the master cylinder which functions in the same manner as a conventional dual master cylinder.

NOTICE: Replace all components included in repair kits used to service this power brake. Lubricate rubber parts with clean, fresh brake fluid to ease assembly. Do not use lubricated shop air on brake parts as damage to rubber components may result. If any hydraulic component is removed or brake line disconnected, it may be necessary to bleed part or all of the brake system. The torque values specified are for dry, unlubricated fasteners. Perform service operations on a clean bench free from all mineral oil materials.

CAUTION: The use of rubber hoses other than those furnished specifically for the Powermaster may lead to functional problems requiring major overhaul.

ON-CAR SERVICE

CAUTION: Failure to fully depressurize Powermaster unit before performing service operations could result in injury to service personnel and damage to painted surfaces.

DEPRESSURIZING POWERMASTER UNIT

! Important

- Depressurize Powermaster before performing any service.
- With ignition off, apply and release brake pedal a minimum of 10 times using approximately 50 pounds force on the pedal.

PRESSURE SWITCH

Figure 2

! Important

- Depressurize Powermaster unit. See CAUTION on page 5D4-2.

↔ Remove or Disconnect

1. Electrical connector (40) from pressure switch (1).
2. Pressure switch (1).
3. O-ring (2).

! Important

- See NOTICE on page 5-1.

↔ Install or Connect

1. New O-ring (2) on pressure switch (1).
2. Pressure switch (1) to 20-27 N-m (15-20 lb-ft).
3. Electrical connector (40) to pressure switch (1).

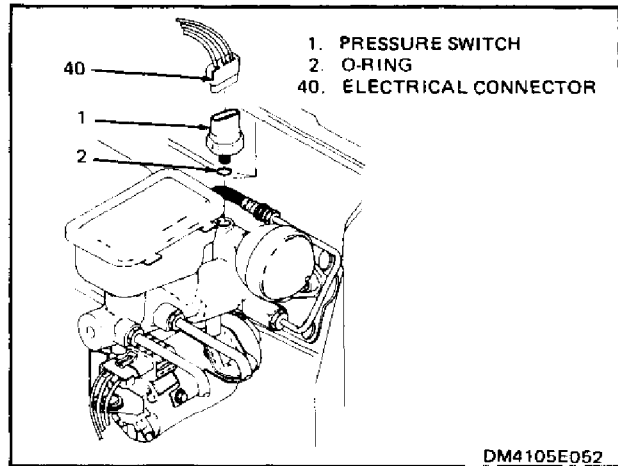

Figure 2 Pressure Switch

ACCUMULATOR

Figure 3

! Important

- Depressurize Powermaster unit. See CAUTION on page 5D4-2.

↔ Remove or Disconnect

1. Accumulator (3).
2. O-ring (4) from accumulator.

! Important

- See NOTICE on page 5-1.

↔ Install or Connect

1. New O-ring (4) on accumulator.
2. Accumulator to 20-27 N-m (15-20 lb-ft).

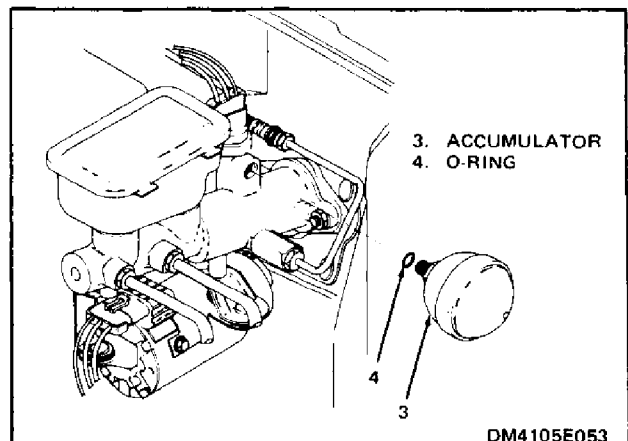

Figure 3 Accumulator

E-H PUMP AND PRESSURE HOSE

Figure 4

! Important

- Depressurize Powermaster unit. See CAUTION on page 5D4-2.

↔ Remove or Disconnect

1. Reservoir cover and diaphragm (32).
2. Hose clamp (9) and end of sump hose (10) connected to E-H pump (8). Drain reservoir pump sump.
3. Electrical connector (41) from E-H pump (8).
4. Pressure hose assembly (11).
 - First, disconnect hose assembly (11) from tube and nut assembly (12).
 - Disconnect other end of hose assembly (11) from E-H pump (8).
5. Three attaching nuts (5) and washers (6).
6. E-H pump (8).

🔍 Inspect

- Grommets (7), and if damaged or deteriorated, replace. Be sure to install new grommets (7) as shown in figure 4.

! Important

- See NOTICE on page 5-1.

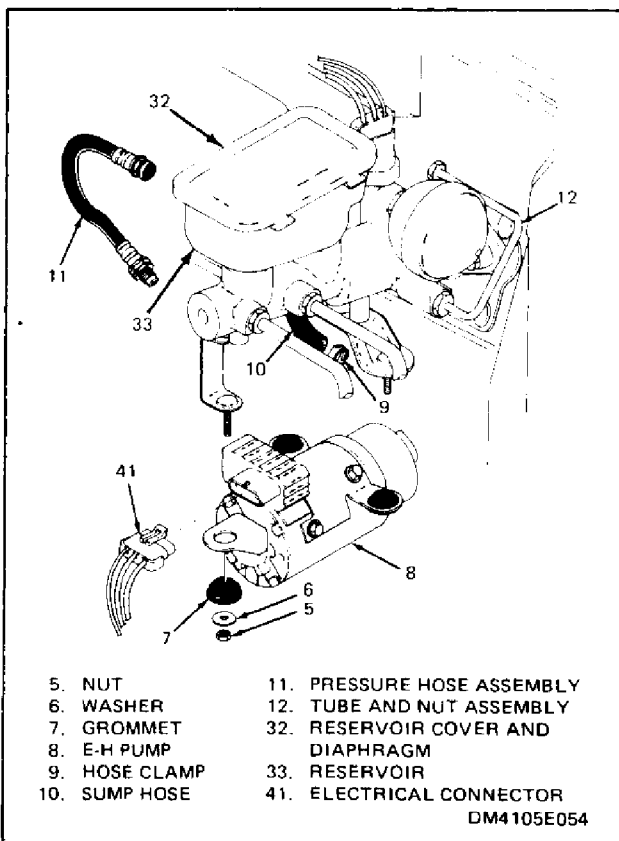

Figure 4 E-H Pump and Pressure Hose

↔ Install or Connect

1. E-H pump (8), washers (6) and attaching nuts (5) to 2.6-4.0 N-m (23-35 lb-in).
2. Pressure hose assembly (11).
 - First, connect end of hose assembly (11) to E-H pump (8) at 13-20 N-m (10-15 lb-ft).
 - Connect other end of pressure hose assembly (11) to tube and nut assembly (12) at 13-20 N-m (10-15 lb-ft).
3. End of sump hose (10) and hose clamp (9) to E-H pump (8).
4. Electrical connector (41) to E-H pump (8).
5. Brake fluid in reservoir (33).

SUMP HOSE, TUBE & NUT ASSEMBLY, AND MOTOR & PUMP BRACKETS

Figure 5

! Important

- Depressurize Powermaster unit. See CAUTION on page 5D4-2.

↔ Remove or Disconnect

1. Reservoir cover and diaphragm (32).
2. Hose clamp (9) and sump hose (10) connected to E-H pump (8). Drain pump reservoir, then reinstall reservoir cover and diaphragm.
3. Hose clamp (9) and sump hose (10) connected to reservoir.
4. Tube and nut assembly (12).
5. Attaching bolts (13) and brackets (14 and 15) (after removing E-H pump, Figure 4, if installed).

! Important

- See NOTICE on page 5-1.

↔ Install or Connect

1. Brackets (14 and 15) with tang on each bracket in locating hole in Powermaster.
2. Attaching bolts (13) to 20-34 N-m (15-25 lb-ft).
3. Tube and nut assembly (12) to 13-20 N-m (10-15 lb-ft).
4. Hose (10) and hose clamps (9).
5. Brake fluid in reservoir (33).

POWERMASTER UNIT

Figure 6

! Important

- Depressurize Powermaster unit. See CAUTION on page 5D4-2.

↔ Remove or Disconnect

1. Electrical connector (40) from pressure switch.
2. Electrical connector (41) from E-H pump.
3. Brake pipes (45) from Powermaster unit (44).
4. Two attaching nuts (43).

5D4-4 POWERMASTER

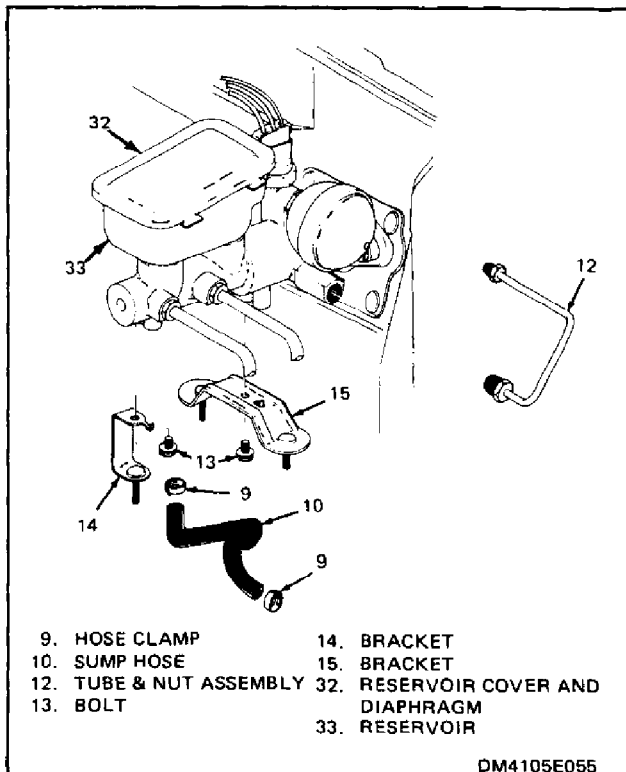

Figure 5 Sump Hose, Tube & Nut Assembly and Brackets

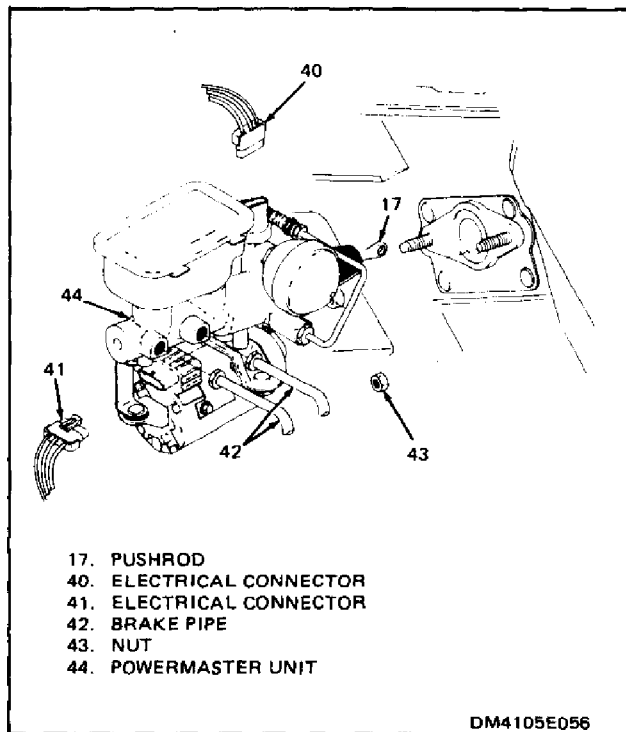

Figure 6 Powermaster Unit

5. Pushrod (17) from brake pedal.
6. Powermaster unit (44).

! Important

- See NOTICE on page 5-1.

↔ Install or Connect

1. Powermaster unit.
2. Pushrod (16) to brake pedal.
3. Attaching nuts (43) to 30-45 N-m (22-30 lb-ft).
4. Brake pipes (42) to Powermaster unit (44). Torque brake pipe nuts to 14-20 N-m (120-180 lb-in).
5. Electrical connector (41) to E-H pump.
6. Electrical connector (43) to pressure switch.

POWERMASTER OVERHAUL

Disassembly

Figures 2, 3, 4, 5 and 7

! Important

- Perform service operations on a clean bench free from all mineral oil materials.

↔ Remove or Disconnect

1. Reservoir cover and diaphragm (32). Empty fluid from reservoir (33).
2. If installed:
 - Pressure switch (1) and O-ring (2) (Figure 2).
 - Accumulator (3) and O-ring (4) (Figure 3).
 - E-H pump (8) and pressure hose assembly (11) (Figure 4).
 - Sump hose (9), clamps (10), tube and nut assembly (12), and brackets (14 and 15) (Figure 5).

Figure 7

! Important

- Use care not to scratch or otherwise damage OD sealing surface at pushrod end of power piston assembly (25) (Figure 7) and bores in Powermaster body (39). These are primary sealing surfaces for this unit.

↔ Remove or Disconnect

1. Retainer (18) from groove in Powermaster body (39).
2. Boot, retainer, pushrod, power piston group (16 thru 25) by grasping and pulling pushrod.

Figures 7 and 8

✦ Disassemble

1. Retainer (16) and boot, pushrod, socket group (17) and piston guide (19) from power piston assembly (25).
2. O-ring (20) from piston guide (19) and O-rings (21) from power piston assembly (25) and piston guide (19).

3. Reaction body group (22) from power piston assembly.
4. Reaction piston (23) and reaction disc (24) from reaction body group (22).

 **Important**

- Do not attempt further disassembly of reaction body group (22) or power piston assembly (25). If damage is noted or fault isolated to reaction body group or power piston assembly, they shall be replaced as assemblies.
5. Primary piston assembly (26) and secondary piston assembly (27 thru 30) by directing a small amount of compressed air into outlet port at blind end of body, other outlet port plugged.
 6. Secondary seal (27), spring retainer (28) and primary seal (29) from secondary piston (30).
 7. Spring (31) from body bore.

 **Install or Connect**

- Powermaster body in vise as shown in Figure 8.

 **Important**

- Do not clamp across Powermaster body.

Figure 7 and 8

 **Disassemble**

8. Reservoir (33) using pry bar (45) as shown in Figure 8.
9. Reservoir grommets (34 and 35).
10. Valve seat and seal (36) and discard.
 - Tap "easy out" into valve seat and pull straight out.
11. Poppet (37) and spring (38) and discard.

 **Clean**

- All parts except pressure switch (1) and E-H pump (8) in clean, denatured alcohol.

 **Important**

- Do not immerse pressure switch (1) or E-H pump (8) in alcohol. Exterior surfaces may be wiped with a clean cloth lightly moistened with denatured alcohol if necessary.
- Dry with filtered compressed air.

 **Inspect**

- All metal parts for cracks, distortion or other evidence of structural damage.
- Primary sealing surfaces on power piston (25) (See Figure 7) for scoring, deep scratches or other damage that would cause leakage. If noted replace power piston assembly.
- Power piston and master cylinder bores in Powermaster body for scoring or corrosion. If noted, replace power brake assembly. No abrasives shall be used.

 **Important**

- Use clean, fresh brake fluid to lubricate parts prior to assembly.
- Lubricate new rubber O-rings, grommets and seals with clean brake fluid just prior to assembly.
- Lubricate master cylinder and power piston bores in Powermaster body before installing parts.

Assembly

Figures 7, 8 and 9

 **Install or Connect**

- Powermaster body (39) in vise as shown in Figure 8.

 **Assemble**

1. New spring (38) and poppet (37) in Powermaster body (39).
2. New valve seat and seal (36) in Powermaster body (39).
3. Bottom out valve seat and seal (36) by threading nut of tube and nut assembly (12) into Powermaster body port.

 **Remove or Disconnect**

- Powermaster body (39) from vise.

 **Assemble**

4. Grommets (34 and 35) into Powermaster body (39).

 **Important**

- Make sure grommets are properly seated.
5. Reservoir (33) to Powermaster body (39) as shown in Figure 9.
 6. Spring (31) in Powermaster body (39).
 7. Secondary seal (27), primary seal (29) and spring retainer (28) on secondary piston (30).
 8. Secondary piston assembly (27 thru 30) in Powermaster body (39).
 9. Primary piston assembly (26) in Powermaster body (39).
 10. Reaction piston (23) and new reaction disc (23) in reaction body group (22).
 11. Two O-rings (21) on power piston assembly (25).
 12. Reaction body group (22) in power piston assembly (25).
 13. Power piston assembly (25) in Powermaster body (42).
 14. One O-ring (21) on piston guide (19); O-ring (20) in piston guide.
 15. Piston guide (19) in Powermaster body (39), over power piston (25).
 16. Retainer (18) while depressing piston guide (19) and power piston (25).
 17. Boot, pushrod, socket group (17), socket into end of power piston assembly (25) and retained with retainer (16).

5D4-6 POWERMASTER

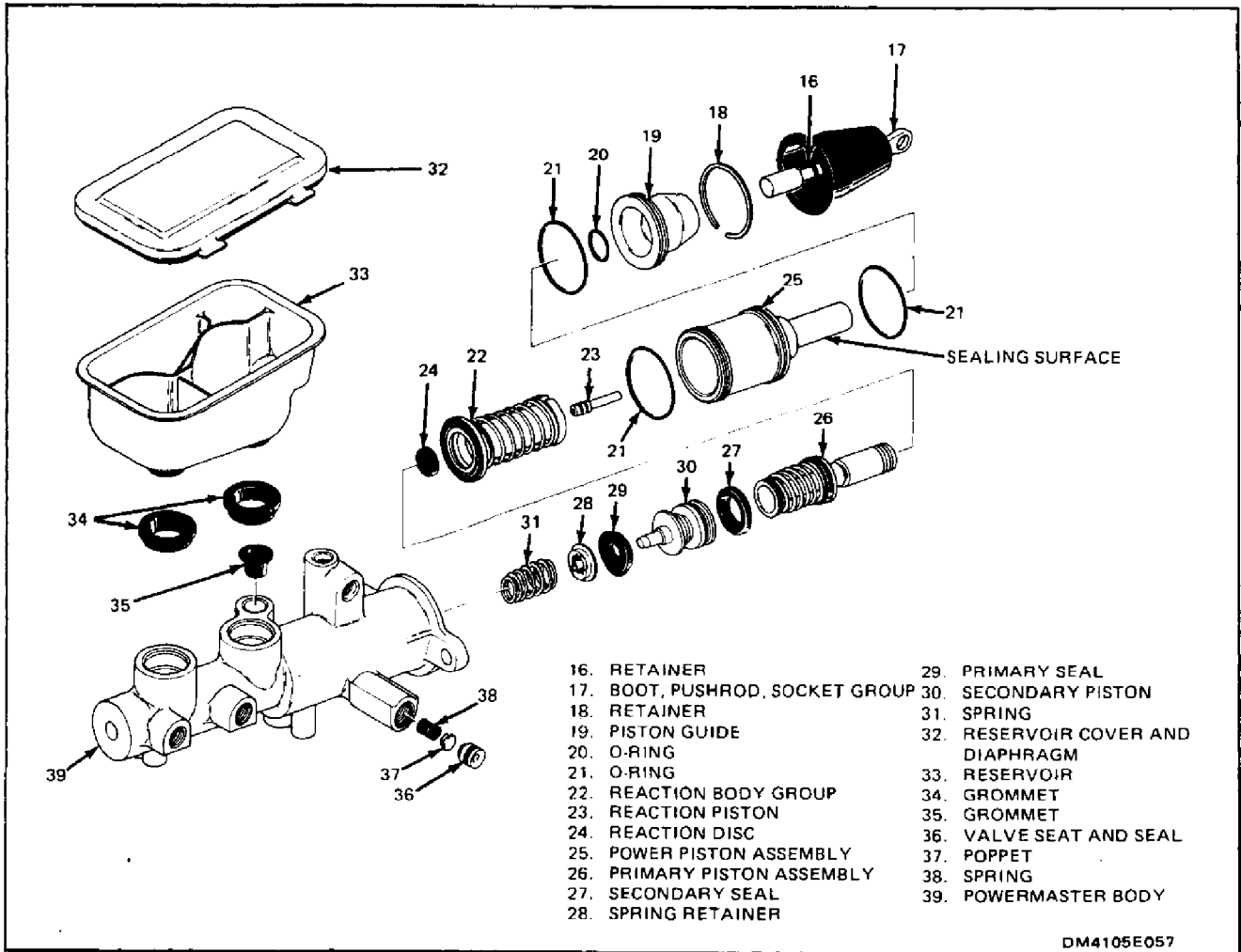

Figure 7 Powermaster Assembly

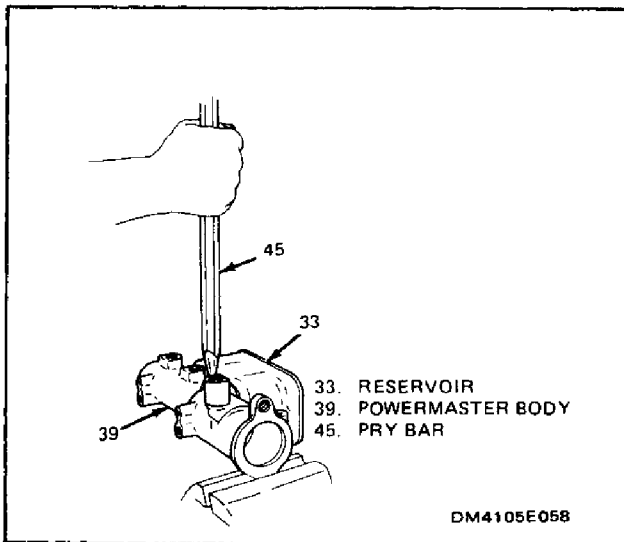

Figure 8 Removing Reservoir

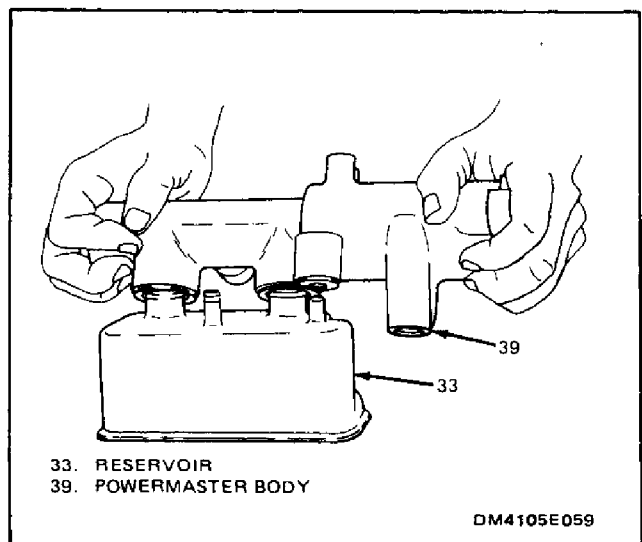

Figure 9 Installing Reservoir

Figures 2, 3, 4, 5 and 7.

Install or Connect

1. External components:
 - Brackets (14 and 15) with bolts (13) (Figure 5).
 - Sump hose (9), clamps (10), and tube and nut assembly (12) (Figure 5).
 - E-H pump (8) and pressure hose assembly (11) (Figure 4).
 - Accumulator (3) and O-ring (4) (Figure 3).
 - Pressure switch (1) and O-ring (2) (Figure 2).
2. Reservoir cover and diaphragm (32) on reservoir (33).

POWERMASTER BLEED AND FILL

★ **FLUID FILLING POWERMASTER**

NOTICE: Bench bleed master cylinder portion of Powermaster before installing the unit on the vehicle.

1. Fill both sides of reservoir to the full marks on the inside of the reservoir. Use only DOT 3 Hydraulic Brake fluid.
2. Turn ignition "on." With the pump running, the brake fluid level in the booster side of the reservoir should decrease as the accumulator is pressurized. If the booster side of the reservoir begins to run dry, add brake fluid to just cover the reservoir port until the pump stops.

NOTICE: Pump must shut off within 20 seconds. Turn ignition off after 20 seconds have elapsed. Perform the following steps if the booster side of the reservoir does not drop.

- Loosen the booster tube and nut assembly from the casting boss figure 5 (Item 12).
 - Wait for brake fluid to gravity bleed from the loosened end of the tubing.
 - When fluid begins to flow, tighten tube nut to 17 N·m (13 lbs. ft.). Check for leaks or flow back into reservoir.
3. Properly install reservoir cover to reservoir.
 4. Turn ignition "off" and apply and release the brake pedal 10 times. Remove reservoir cover and adjust booster fluid level.
 5. Perform Steps 2 thru 4 again.
 6. Install reservoir cover to reservoir.

NOTICE: Refer to the PowerMaster Diagnosis if:

- The pump does not shut off within 20 seconds.
- The booster reservoir level does not stabilize.
- The pump cycles without brake application.

BLEEDING MASTER CYLINDER SECTION OF POWERMASTER

MANUAL METHOD

1. Fill reservoir to indicated full marks inside reservoir with brake fluid as specified on cover. Properly install reservoir cover assembly.
2. Remove brake line connectors from master cylinder outlet ports and allow cylinder to gravity bleed until fluid runs out of the brake line ports. Recon-

nect brake lines to master cylinder ports. Tighten connector closest to cowl.

3. Have assistant slowly apply brake pedal to full travel at approximately 50 pounds force (no power assist). Tighten forward brake line connector, then release pedal fully. Wait 5 seconds. Reapply brake pedal and hold. Open forward connector 1/2 turn to purge air from connector. Tighten connector, then release brake pedal again.
4. Repeat step 3 until all air is purged from forward connector port. Tighten connector to specifications. Maintain reservoir brake fluid levels.
5. Repeat steps 3 and 4 except at rear brake line connector.
6. With brake lines, cylinders and master cylinder fully bled, check pedal travel and observe that brake warning indicator does not light during hard apply.

PRESSURE BLEED

NOTICE: Pressure bleeding equipment must be of the diaphragm type. It must have a rubber diaphragm between the air supply and the brake fluid to prevent air, moisture and other contaminants from entering the hydraulic system.

1. Fill the master cylinder section of reservoir approximately half full with new brake fluid. See fluid specified on reservoir cover.
2. Install the special bleeder adapter J-35360 on Powermaster.
3. Charge bleeder ball to 20-25 psi.
4. Connect line to adapter. Open line valve and depress bleed-off valve on top of adapter until a few drops of fluid appear.
5. Hoist car.
6. Attach bleeder hose to bleeder valve and submerge opposite end in clean container partially filled with brake fluid.
7. Open bleeder valve 1/2 to 3/4 turn and allow fluid to flow until no air is seen in fluid.
8. Bleeding sequence:
 - a. Right rear
 - b. Left rear
 - c. Right front
 - d. Left front
9. After bleeding, torque brake line connectors to 10-15 lb-ft.

FUNCTIONAL CHECK AND DIAGNOSTIC PROCEDURE

PRELIMINARY PROCEDURE

1. Complete the fluid filling and bleeding procedures per POWERMASTER BLEED AND FILL instructions. Assure that pump cycle time and reservoir fluid levels are maintained within prescribed limits. Brake fluid temperature at 60°-80°F. (Warm fluid to 60°F min by cycling pump.)
2. Fully discharge accumulator by making 10 medium brake applications with ignition "OFF".
3. Inspect for fluid leakage at brake pedal push rod,

5D4-8 POWERMASTER

reservoir cover, hose and pipe connections, reservoir attaching points, pressure switch and accumulator.

4. Remove pressure switch from Powermaster and install J-35126 test gage adapter. Reinstall pressure switch in test adapter. Attach pressure switch electrical connector. Close bleed valve.

FUNCTIONAL CHECK SEQUENCE (TEST)

1. Turn ignition "ON". E. H. pump will run and then shut off. (Do not allow pump to run more than 20 seconds.)
2. Observe that pump stops at 635-735 psi reading on test gage. (Pressure will settle to a slightly lower value after shut off and then remain steady—observe for 1 minute).
3. Slowly bleed off accumulator pressure with bleed valve—returning fluid to pump reservoir. Observe that pump turns on again at 490-530 psi.
4. Have assistant slowly apply brake pedal (reservoir cover off) and hold at steady medium force. Observe pressure gage for indication of continuous pressure drop. Pressure drop rate should not cause pump to recycle within 30 seconds of first apply.
5. Turn ignition "OFF" and remove pressure switch electrical connector. With ohmmeter connected to switch terminals B/C (see figure 10) and ignition "OFF", slowly bleed off accumulator pressure. B/C should close at 355-435 psi. This is the low pressure warning signal.
6. Continue to bleed off accumulator pressure and note sudden drop off in gage pressure reading at 200-330 psi. This sudden drop is at the accumulator pre-charge pressure.
7. Assure that pump sump fluid level is at the "FULL" mark on the inside of the reservoir when accumulator is fully depressurized.
8. Turn ignition "ON" and cycle pump several times to remove air by opening and closing bleed valve. Pump "ON" time should now be less than 10 seconds each cycle.
9. During pump "ON/OFF" cycles, note sump reservoir fluid level. It will normally be just covering the sump hose port when pump is "OFF", and 1/2 full when pump comes "ON".

FINAL EVALUATIONS

1. Depressurize accumulator and remove J-35126 test gage adapter. Reinstall pressure switch and electrical connector and reservoir cover.
2. With Powermaster functioning normally, apply brake pedal and note pedal travel. Pedal should not creep at steady pressure. Brake warning light should not indicate pressure differential between pressure circuits. For diagnosis—use typical master cylinder information.
3. Observe running motor and pump sound from driver's seat. Compare to know good unit.
4. Consult the diagnostic symptom chart for conditions and performance values which differ from normal.

POWERMASTER DIAGNOSIS

Reference Functional Check Procedure (Test)

Tools • J-35126 test gage adapter

- Volt/Ohmmeter
 - 6" clear plastic tubing (1/4" diameter)
1. Symptom: Brake Warning Light "ON" After Engine Start
 - Parking Brake Applied
 - Temporarily release parking brake—observe light. Reapply if light remains "ON".
 - Partial Failure in Brake Hydraulic Pressure Circuit
 - Evaluate for excessive brake pedal travel
 - Evaluate for hard brake pedal force to stop
 - Evaluate for excessive stopping distances and early wheel lock-up tendency.
 - Repair as necessary
 - Low Pressure in Powermaster Accumulator
 - Electrical failure—check ignition, 30 amp fuse, pressure switch "A/C" terminals motor/relay, connectors, wiring.
 - Low fluid in reservoir—(see fill and bleed procedure)
 - Faulty Warning Light Pressure Switch
 - Check warning switch (1) actuation pressure at terminals B/C (Test 5)
 2. Symptom: Pump Motor Will Not Run
 - Electrical Failure—Check ignition, 30 amp fuse, pressure switch terminals "A/C" closed, connector terminals, motor/relay and wiring
 3. Symptom: Pump Motor Runs—Does not Shut Off in 20 Seconds
 - Turn Ignition "OFF" after 20 Seconds (each evaluation)
 - Check reservoir fluid level—(see fill and bleed procedure)
 - Check reservoir port A for backflow (Figure 10)
 - replace power piston (25)
 - Check pump pressure (Test 2)
 - pressure low
 - check pressure line (11, 12) for obstruction
 - replace pump and motor (8)
 - pressure high
 - replace switch (1) if higher than normal
 - replace pump (8) if lower than normal cut-off
 4. Symptom: Pump Self Cycles Without Brake Apply
 - Check for accumulator precharge pressure (Test 6) — replace accumulator (3) if low. Re-check self cycle.
 5. Symptom: Pump Self Cycles While Holding Steady Brake Apply
 - Does not self cycle without brake apply (Symptom No. 4)
 - Check for accumulator precharge pressure (Test 6) — replace accumulator (3) if low. Re-check self cycle.

- Check for fluid backflow at reservoir port A (Figure 10)
 - replace power piston (25)
- 6. Symptom: Fluid Level in Pump Reservoir Does Not Cycle Between Full and Nearly Empty when Accumulator is Fully Charged and Fully Depressurized (Test 7)
 - Check for air in fluid—cycle 5-10 pump cycles to remove air
 - Check accumulator precharge pressure (Test 6)
 - replace if low
- 7. Symptom: Fluid Level in Pump Reservoir Does Not Cycle Between Half Full and Nearly Empty at Pressure Switch Limits (Test 9)
 - Check for reservoir full at fully depressurized accumulator
 - Check for accumulator precharge pressure if reservoir level after pump cycle is not nearly empty
- 8. Symptom: Pump and Motor Noisy (Final Evaluation 3)
 - Check for grounded tube and hose (12, 13), motor (8)
 - Check for reservoir fluid level
 - Replace motor mount grommets
- 9. Symptom: Fluid Leakage (Preliminary Procedure 3)
 - Check pump reservoir for excess fluid fill with accumulator fully depressurized
 - Check for tight reservoir cover and diaphragm (32)
 - Wipe dry and identify source of leakage
 - overhaul as necessary
- 10. Symptom: Pump Cycle Time at Pressure Switch Limits Exceeds 10 Seconds (Test 8)
 - Check for air in system—recycle 5-10 pump cycles to remove air
 - Check for normal pressure switch points
 - Check for obstructed pump inlet and outlet fluid circuits
 - Check for faulty pump

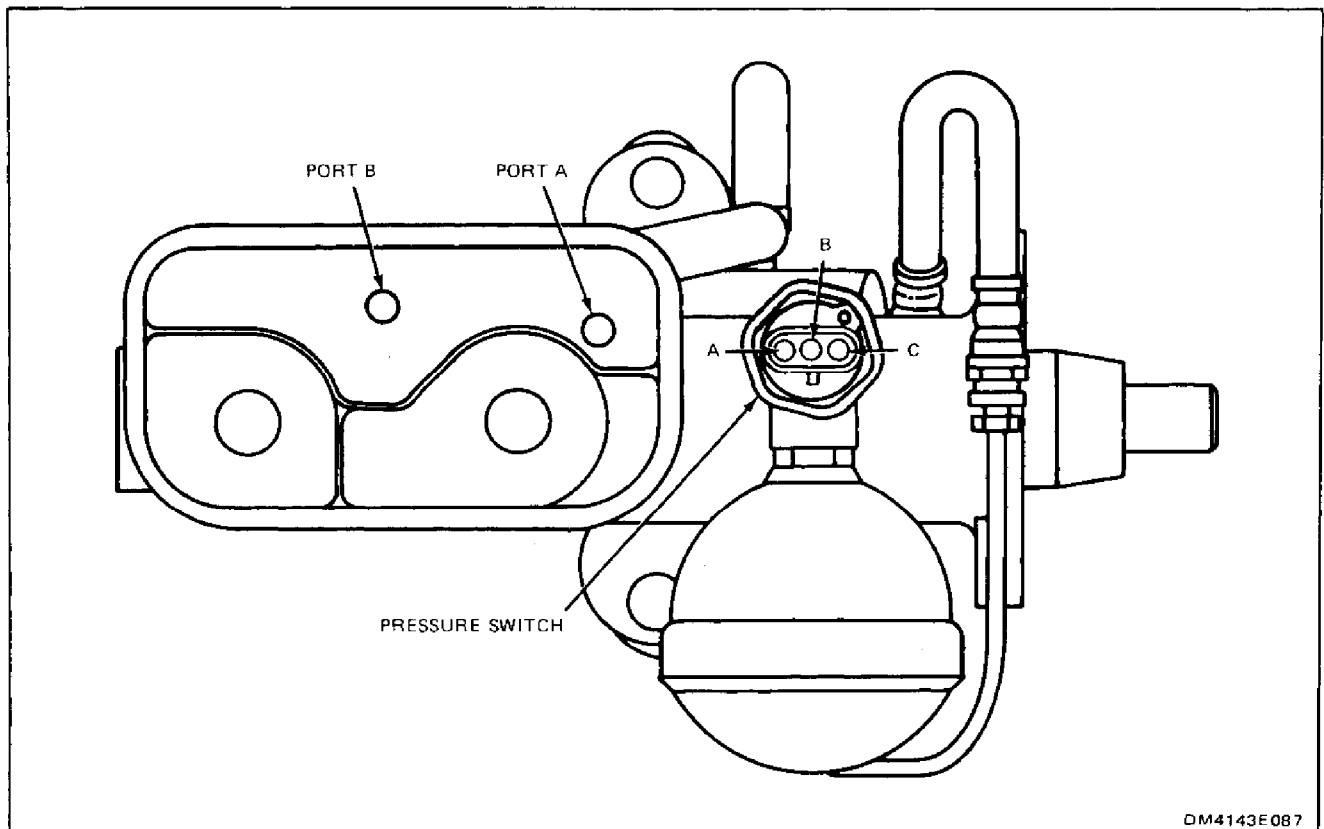

DM4143E087

Figure 10 Ports and Terminals